

MULTI FUNCTION & EQUAL ACCURACY COUNTER

F1000L / F2400L / F2700L

OPERATING MANUAL

TABLE OF CONTENTS

SECTION	TITLE	PAGE
1.	INTRODUCTION SPECIFICATION	2
1.	INTRODUCTION	2
2.	SPECIFICATION	2
2.	OPERATING THEORY	2
3.	OPERATION	4
1.	INTRODUCTION	5
2.	PREPARATION FOR USE	5
3.	FRONT PANEL FEATURE	5
4.	REAR PANEL FEATURE	6
5.	OPERATION	7
5-1.	Frequency measurements	7
5-2.	Period measurements	7
5-3.	Totalize measurements	7
5-4.	Check mode	7
4.	CALIBRATION	9
1.	INTRODUCTION	9
2.	TEST INSTRUMENTS REQUIRED	9
3.	TIME BASE FREQUENCY ADJUSTMENT	9
4.	TRIGGER LEVEL ADJUSTMENT	10

SECTION 1

INTRODUCTION & SPECIFICATION

1. INTRODUCTION

This instrument is a 10Hz to 1000MHz, 2400MHz, 2700MHz multiple-function & equal accuracy counter.

It features a eight digit, bright seven segment LED display, four function performance, LOW power consumption circuit design, small size, Light weight, high stabilized crystal oven oscillator for measurement of accuracy and full input signal conditioning.

The four functions are frequency, period, totalize and Self check.

This is accomplished by a single chip microcontroller. The input signal can be conditioned by attenuation. It is recommended that whole information and details should be read and understood before attempting to operate the instrument for correct operation and best results.

2. SPECIFICATIONS.

The pertinent specifications are listed as follows:

Frequency measurements.

CHANNEL A.

- Range : 10 Hz to 10MHz direct counter
 : 10 Mhz to 100MHz prescaled by proportion
- Resolution : direct counter : 1,10,100Hz switch selectable.
 : prescaled : 10,100,1000Hz switch selectable.
- Gate time : 0.01s, 0.1s, 1s switch selectable.
- Accuracy : $\pm 1\text{count} \pm \text{timebase error} \times \text{measured}$

CHANNEL B

Table 1

Model Number Item	F1000L	F2400L	F2700L
Range	100MHz - 1GHz	100MHz - 2.4GHz	100MHz - 2.7GHz
Resolution	100Hz, 1KHz, 10KHz	100Hz, 1KHz, 10KHz	100Hz, 1KHz, 10KHz
Gate Time	0.01s, 0.1s, 1s	0.01s, 0.1s, 1s	0.01s, 0.1s, 1s
Accuracy	$\pm 1\text{count} \pm \text{timebase error} \times \text{measured frequency}$		

Period Measurements

Input : Channel A

Range : 10Hz To 10MHz

Resolution : 10^{-7} s, 10^{-8} s, 10^{-9} s switch Selectable.
 Accuracy : ± 1 count \pm timebase error \times measured period
 Totalize measurements
 Input : Channel A
 Range : 10Hz To 10MHz
 Resolution : ± 1 Count of Input.
 Check : 8 Bits Repeating Display 0~9 Together

B. Input Characteristics

CHANNELA.

Input Sensitivity:

10 Mhz range : 10Hz ~ 8MHz 20m Vrms
 8MHz ~ 10MHz 30m Vrms
 100 Mhz range : 10Hz ~ 8MHz 20m Vrms
 80MHz ~ 10MHz 30m Vrms

Attenuation : $\times 1$, $\times 20$ fixed

Filter (CH A only) Low pass: Ac 100KHz -3dB

Impedance : Approx. 1M Ohm less Than 35pF

Maximum voltage without damage: 250v(DC+ Acrms)

CHANNELB.

Input Sensitivity: 20m Vrms

Impedance : Approx. 50 Ohm

Maximum Voltage Without Damage: 3V

C. Time Base

Time Base Frequency : 10MHz

Short Term Stability : $\pm 3 \times 10^{-9}$ for 1s Average

Long Term Stability : 2×10^{-6} Month

Temperatures : $\pm 1 \times 10^{-6} \text{ } ^\circ\text{C}$ To 4°C

Line Voltage : $\pm 1 \times 10^{-3}$ For 10% Change

D. General

Display : 8digits, 0.39 inch red led display with decimal point, gate, overflow,
 KHz, Mhz and μ S
 indication.

power requirement: line 220V \pm 10% 45hz ~ 70hz

warm - up time : 20 minutes when cold started at 25°C

temperature : rated range of use: -5°C ~ $+ 50^\circ\text{C}$

storage and transport : -40°C ~ $+ 60^\circ\text{C}$

Humidity : operating : 10~ 90% RH

storage : 5~95%RH

Dimension and weight : width : 207mm

height : 85mm

depth : 255mm

weight : 2kg

E. Supplied Accessories : power cord

Operating Manual

SECTION 2 OPERATING THEORY

The operating theory is equal accuracy measurement in this instrument.

In reserved gate time, counter 1 counts N_x for measured integral pulses, counter 2 counts N_0 for standard pulses. Frequency F_x and period P_x of the measured signal can be determined by calculating formulas easily.

Frequency $F_x = N_x / T_x$

period $P_x = T_x / N_x$

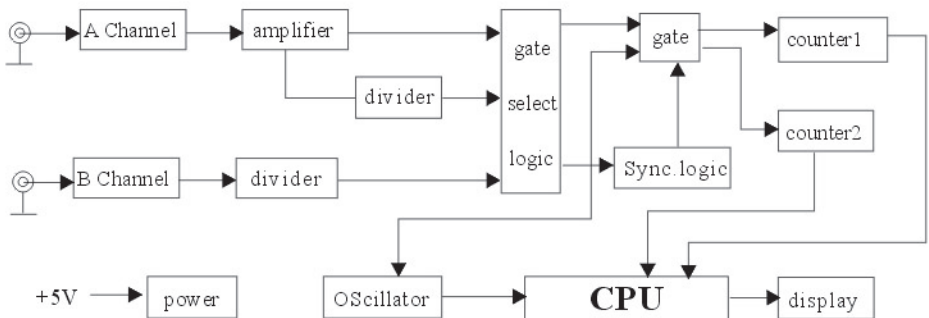

Fig 2-1

SECTION 3 OPERATION

1. INTRODUCTION

This section provides complete operating information for this multifunction & equal accuracy counter. This section includes a description of all front panel controls, connectors and indicators, operating instructions. Operator's maintenance.

2. PREPARATION FOR USE

1) Power requirements.

It requires a power source of 220V AC 45 to 70Hz single phase.

Power consumption is 10 watts maximum.

2) wait about 20 minutes for correct measurement until the crystal oven oscillator gets stable in aging.

3. FRONT PANEL FEATURES

Fig 3-1

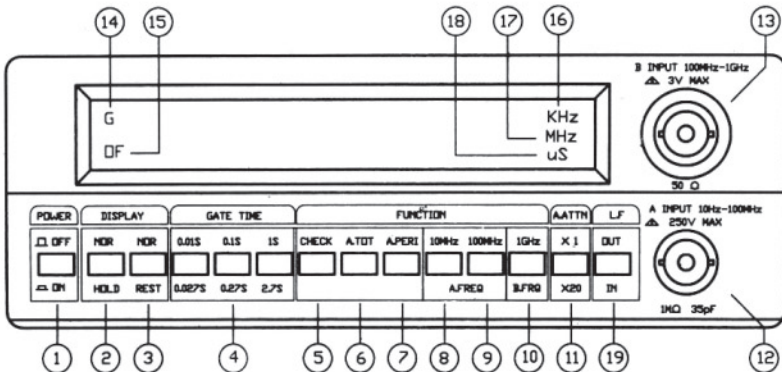

Fig.3-1 shows the front panel

- 1) Power Switch : To turn on, depress pushbutton. Display this instrument model "F-1000-L" in 2 seconds
- 2) HOLD : in hold, switch in, the measurement (except for totalize) in progress is stopped.
- 3) RESET : when pressed, immediately reset the counter to begin a new measurement, usually used in the totalize mode to begin a new measurement.
- 4) GATE TIME : for frequency measurement, this switch is used to change gate time. When in the period measurement mode, it is used to change the multiplier factors.
- 5) CHECK : Check this instrument status and 8 bits repeating display 0~9 together.
- 6) A.TOT. : Totalizer measurement. (Channel A input)
- 7) A.PER1. : With this switch in, placed in period mode.
- 8) A.FREQ. 10MHZ : With this switch in, placed in 10 mhz range frequency mode. (Channel A input)

9) A.FREQ. 100MHZ : With this switch in , placed in 100mhz range frequency mode . (Channel A input)

10) B.FREQ(channel B input)

Table 4

MODEL NO	F1000L	F2400L	F2700L
SWITCH	B.FREQ.1GHz	B.FREQ.2.4GHz	B.FREQ.2.7GHz
RANGE	100MHz- 1GHz	100MHz- 2.4GHz	100MHz- 2.7GHz

- 11) ATT : Input Signal Attenuator Switch.
When pressed, the sensitivity is attenuated by factor 20 input signal. (Only A input)
- 12) A.INPUT : Channel A input connector.
- 13) B.INPUT : Channel B. Input connector.
- 14) Gate Indicator : Displays the opened or closed state of the GATE. When GATE is open. Indicator is lit.
- 15) OVERFLOW indicator : Indicates Overflow Of 8 Digits
- 16) KHZ Annunciator
- 17) MKZ Annunciator
- 18) μ S Annunciator
- 19) Lowpass Filter : Ac. 100KHz -3db
- * All Function Keys To turn off Display Model : "F-1000-L"

4. REAR PANEL FEATURES

Fig 3-2

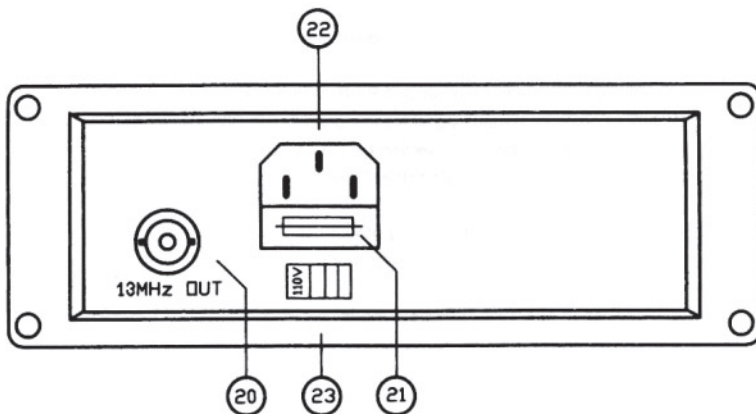

Fig 3-2 Shows the rear panel.

20) 13 Mhz OUT : Output connector for internal reference OSCillator. This connector provides a 13 Mhz signal. It may be used as a reference signal for other frequency counters.

- 21) Fuse AC power protection (0.3A.)
- 22) AC INLET Provides connection to AC power.
- 23) AC SELLECTOR 115V or 230V.

5. OPERATING CHARACTERISTICS

The following paragraphs describe the operating ranges and resolution for frequency. Period, totalize and check function.

5-1. Frequency Measurements.

Perform frequency measurement as follows:

- 1) Press the POWER switch to the ON position.
- 2) Press the FREO. Switch to select the frequency mode of operation.
- 3) Select the desired gate time.
- 4) Connect the input signal to the front-panel BNC connector.
- 5) Set ATT. To desired position. If input signal level is greater than 300mV. Depressing the switch will decrease the triggering sensitivity of the input, section by a 20 and reduce errors.
- 6) Read the frequency on display, and observe the unit of measurement indication to the right of the display.

5-2. Period Measurements.

Perform period measurements as follows:

- 1) Press the POWER switch to the ON position.
- 2) Press the APERI Switch to select the period mode of operation
- 3) Select the desired PERIMUL TI
- 4) Connect the input signal to the front-panel A INPU TBNC connector.
- 5) Set ATT. To desired position. If input signal level is greater than 300m V. Depressing the ATT switch will decrease the triggering sensitivity of the input section by a 20 and reduce errors.
- 6) Read the period time on display. And observe the unit of measurement indication to the right of the display.

5-3. Totalize Measurements.

Perform to talize measurements as follows:

- 1) Press the POWER switch to the ON position.
- 2) Press the A. TOT switch to select the totalize mode of operation, and the RESET switch to initialize the counter.
- 3) Connect the input signal to the front-panel A. INPU TBNC connector.
- 4) Set ATT. To desired position, If input signal level is greater than 300mV. Depressing the ATT switch will decrease triggering sensitivity of the ininput section by a 20 and reduce errors.
- 5) Read the accumulated total on display after HOLD switch in.

5-4. Check mode.

The self-check mode provides a means of verifying proper overall operation of counter. Excluding input section, tem base accuracy, and time base dividers used in the peios mode.

- 1) Press the POWER switch to the ON position.
- 2) Press the check switch to select the self-check mode.
- 3) Press the IS GATE TIME Selector: the display thould read

100000.000

With the instrument gating once every second.

- 4) Press the 0. IS GATE TIME selector: the display should read

10000.00

With a 100-millisecond gae time.

- 5) Press the 0.01S GATE TIME selector, the dispaly should read

10000.0

With a 10-millisecond gate time.

SECTION 4 CALIBRATION

1. INTRODUCTION

Calibration is limited to adjustment of the time base oscillator frequency and the trigger level.

Time base oscillator adjustment should be made whenever the oscillator is determined that accuracy of the counter is not within the accuracy desired. Perform time base oscillator adjustment in an environment having an ambient temperature of +22°C to 25°C (72° F to 77° F). Allow the instrument to warm up at least 30 minutes with case on before adjusting the time base.

WARNING

MAINTENANCE DESCRIBED HEREIN IS PERFORMED WITH POWER SUPPLIED TO THE INSTRUMENT, AND PROTECTIVE COVERS REMOVED. SUCH MAINTENANCE SHOULD BE PERFORMED ONLY BY SERVICE-TRAINED PERSONNEL WHO ARE AWARE OF THE HAZARD INVOLVED (FOR EXAMPLE, FIRE AND ELECTRICAL SHOCK). WHERE MAINTENANCE CAN BE PERFORMED WITHOUT POWER APPLIED, THE POWER SHOULD BE REMOVED.

2. TEST INSTRUMENTS REQUIRED.

INSTRUMENT	Brief specification
1) Quartz Oscillator	Range: 13MHz, 1GHz(F1000L) 13MHz, 2.4GHz(F2400L) 13MHz, 2.7GHz(F2700L) Temperature coefficient: $\pm 1 \times 10^{-6}$
2) sine wave generator	Range: 10Hz- 1MHz, 1KHz-1GHz

3. TIME BASE FREQUENCY ADJUSTMENT

A. Time Base

- 1) Remove the counter from case.
- 2) Select A 10 MHz output on the quartz oscillator < i.e. Housw standard > and connect the 10 Mhz signal to the counter A. INPUT.
- 3) Set the front panel controls as follow.
POWER.....ON
NOR / HOLFNOR
GATE TIME 1s
FUNCTIONA.FRO.10MHZ
ATTX1
- 4) While observing the counter display. Adjust the time base oscillator control (C5 located on the oven) to obtain a reading of 10000.000 \pm 1 digit.

B. Time Base

- 1) Remove the counter from the case.
- 2) Select a 1GHz / 2.4GHz/ 2.7GHz output on the quartz. Oscillator (i.e. House standard) and connect the counter B. INPUT.
- 3) Set the front panel controls as follow:
POWER ON
NOR/HOLD.....NOR
GATE TIME.....1s
FUNCTION.....B.FREQ
- 4) While. Opsring the counter dispay. Adjust the time base oscillator(C28 located one the oven)to obtain a reading of
1000.0000 ±1(F1000L)
2400.0000 ±1(F2400L)
2700.0000 ±1(F2700L)

4. TRIGGER LEVEL ADJUSTMENT

- 1) Remove the counter from the case.
- 2) Set sine wave generator controls for 10 Hz and 10MHz at exactly 20 m vrms amplitude.
- 3) Connect generator to A INPUT connector of the from pannel.
POWERON
NOR/HOLDNOR
GATE TIME1s
FUNCTION.....A.FRO.10MHZ
ATT×1
- 4) While observing the counter, dispay, adjust the trgger level control (RP 1 on the pcb) to cbtain a reading of stable value.

Fig 4-1

